

5940 G – Specifications

Print features

- Printhead DPI
 - Vertical DPI: 200
 - Addressable jets: 256
 - Nozzles: 512

Print density	DPI - Ink drops per inch	Typical speed (m/min)	Maximum speed* (m/min)
1	150 x 200	121.9	182
2	300 x 200	61	91
3	450 x 200	40.6	61
4	600 x 200	30.5	45
5	750 x 200	24.4	36

- Print densities available: 1 to 10
- Encoder scaling: Allows for conveyor line speed matching and for higher print speeds with a reduction in the print resolution
- Print area: Maximum/printhead print height: 65 mm (2.56") Print length: 3 m (118.11")
- Print fonts: Full TrueType fonts supported
- Printing of real-time clock (hr/min/sec), dates and auto updating best before dates and serial numbers
- Barcodes (linear and 2D): ITF, Code 39, Code 128, GS1-128, EAN 128, EAN 8, EAN 13, UPC-A, UPC-E, DataMatrix, RSS linear, RSS composite, QR, RSS 14, RSS expanded, PDF 417

Software

- Compatible with Systech Packaging Intelligence Suite™ software including:
 - CoLOS® Base (minimum requirement)
 - CoLOS Line (optional)
 - CoLOS Factory (optional)
- For more information on Packaging Intelligence solutions please visit systechone.com

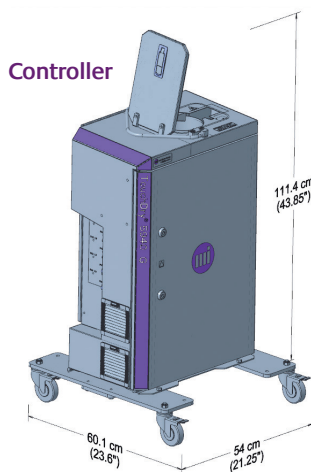

Operations

Controller, options, and accessories setup

- Choose one, two, three, or up to four printheads
- Printhead orientations: Vertical, horizontal, and down jetting
- Up to 25° from vertical printhead tilt angle (tilted conveyor)
- Optional remote user interface: 10" color LCD touchscreen for image selection, print preview, variable data entry, diagnostics and system setup
- Web UI (user interface)
- Large central ink reservoir with umbilicals to printheads
- Ink replenishment: User prompted to add ink. Can be added without suspending printing
- Encoder options:
 - Internal: For fixed conveyor speed printing
 - External: For optimizing print quality (Recommended for bar code printing)
- Photo-edge sensors: Print (trigger) signal and a maximum of four per system

System operation

- Selectable multi-language menus
- Image preview
- Access levels password protection
- Three levels of user messages: Information, warnings, and errors
- Full system diagnostic menu

Interfaces and communication

- Communications interfaces/protocols: Ethernet, HJC, DCP, NGPCL, PackML
- File transfer and firmware upgrade by USB port
- Hardware I/O: 5 inputs/5 outputs, all programmable
- Optional integrated expansion I/O board for an additional 5 inputs/5 outputs, all programmable
- Standard scanner interfaces: 1D/2D scanner by power over ethernet (POE) and handheld scanner (USB)
- Remote keyboard interface

Limited daily maintenance

- Printhead daily care: Wiping, purging and test print capability

Printhead

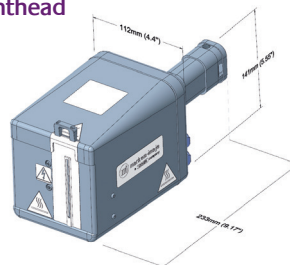

Other characteristics

- Weight: Printhead (PH): 2.1 kg
 - Controller: 2PH - 50 kg. / 111 lbs., 4PH - 53 kg. / 116 lbs.
 - Controller base with castors: 16.8 kg
- Touch Dry® hot melt inks available in various series, colors packaged in bottles
- Electrical and environmental: 100-240VAC, 50/60Hz

System	Typical operating power	Power during start-up
1 head	250 watts	1000 watts
2 heads	375 watts	1200 watts
3 heads	500 watts	1400 watts
4 heads	600 watts	1600 watts

- Operating environment of 0 to 40 °C (32 to 104 °F)
- IP54 (cabinet only)
- Manuals: Safety manual included, all other manuals are accessed via Markem-Imaje website
- Local language versions for the color user interface

Options

- Sturdy printhead slide assembly for best print quality, allowing for misshapen boxes
- 10.1" Remote user interface (RUI)
- 5 light signal tower assembly with audible alarm
- Scanners: 1D and 1D/2D scanners
- Additional I/O: 5 inputs, 5 outputs, all programmable

Services and support

- Personalized, scalable rental program*
- Flexible consumable, maintenance and professional/training services agreements
- Remote expert resources with live helpdesk and video support
- Miva virtual assistant for 24/7 self-service
- On-demand consumables and spares, including an online ordering portal**

Remote user interface

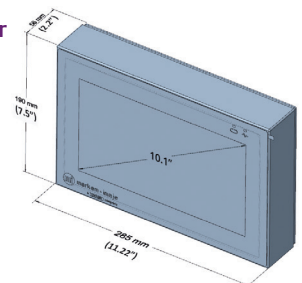

*Maximum speed is application specific **Based on printer model and local availability

We reserve the right to amend the design and/or specifications of our products without notice.

Markem-Imaje
50 Congress Street
Keene, NH 03431
United States of America
Tél. : 800-258-5356

100 Chastain Center Blvd.
Suite 165 Kennesaw, GA 30144
United States of America
Tél. : 770-421-7700

 **markem·imaje**
a **DOVER** company

To learn more, visit markem-imaje.com



markem·imaje

a DOVER company



5940 G | GREATER throughput,
high-quality codes

Touch Dry® High Resolution Inkjet Coders

Intelligence, beyond the mark

The 5940 G sets the standard of coding quality, compliance, operational efficiency and reduced total cost of ownership (TCO) with a sustainable solution. Greater throughput and compliant barcodes including GS1-128 requirements.

Your challenges

- Achieving high quality, compliant packaged product without the hassle and added cost of labels.
- Finding reliable equipment that is easy to integrate, operate and maintain

Our solution

The piezo inkjet drop-on-demand printer offers a faster return on investment by boosting production throughput while enabling manufacturers to improve their supply chain management through traceability and brand protection. **That's printing intelligence beyond the mark.**

Key benefits

- Superior coding solution ensures readability and compliance
- A solution designed for increased availability and production output
- Legendary 5000 series advantages: a sustainable investment



Maximized uptime tha

Superior coding solution ensures readability and compliance

Proven code quality made even better with patent pending Intelli'Flow™ technology

Intelli'Flow technology keeps the printhead jets clear by preventing ink and dust buildup through an innovative air flow design; additionally, a filtering mechanism prevents air bubbles from forming in the ink during high-speed printing ensuring scannable and well-defined codes.

Highest quality codes for GS1-128 compliance

For C grade barcodes trust our Touch Dry® inks that solidify on contact unlike liquid inks that lose resolution by spreading along corrugate fibers. And our exclusive high optical density inks deliver increased contrast on barcodes. A variety of colored inks are available to further emphasize your brand.

Code verification via advanced vision inspection

You need your coding to be rock-solid reliable. Our proven verification and automated inspection solutions ensure you consistently ship high-quality readable, accurate codes.



Thanks to easy maintenance and robust design



A solution designed for increased availability and production output

Maximized uptime thanks to easy maintenance and robust design

- The 5940 G has been **designed for serviceability—an average of 15-minutes**—setting new market standards and driving OEE improvements.
- **IP54-rated** controller improves dust resistance and performs in tough manufacturing environments (0-40°C)
- **The 10” color touch user interface** has an intuitive menu structure for faster print selection and reduced downtime between jobs.
- **No plant air.** Air flow is generated internally rather than requiring external air compressors

Faster ramp-up to increase production time – up to 6.9%** Reduce start-up time by 67% with patent pending reservoir heating or use the pre-shift automatic start timer.

43% less operator intervention to boost productivity

With a 75% larger ink container than most competitors, the 5940 G ensures 43% less operator intervention and there is no need to stop the line to refill ink—refill on the fly! With no solvents to mix, consumables management is clean and easy.

Efficiency and data integrity through greater automation

The 5940 G supports 1D and 2D scanners for lookup and verification, comes standard with five inputs and five outputs, all programmable. There is an option to expand to an additional five inputs and five outputs, all programmable too. Can integrate with PLCs and corporate databases.

Legendary 5000 Series advantages: a sustainable investment

Worry-free code management

Thanks to our Systech Packaging Intelligence Suite™, message coding and job creation has never been easier. Expand your printer’s capabilities with additional solutions to drive efficiency and maximize uptime while ensuring your packaging and coding is accurate and traceable.

Environmentally Friendly

Our Touch Dry inks are free of odors and Volatile Organic Compounds (VOC), comply with global food packaging guidelines and are supplied in highly recyclable PP-Polypropylene containers.

Reduced preprint and labels

High resolution inkjet coders allow you to reduce your preprinted corrugate case inventory thanks to late-stage customization capabilities. Avoids the use of expensive labels and avoids the disposal of label waste and cores.

