

The Total Package... beginning to end.

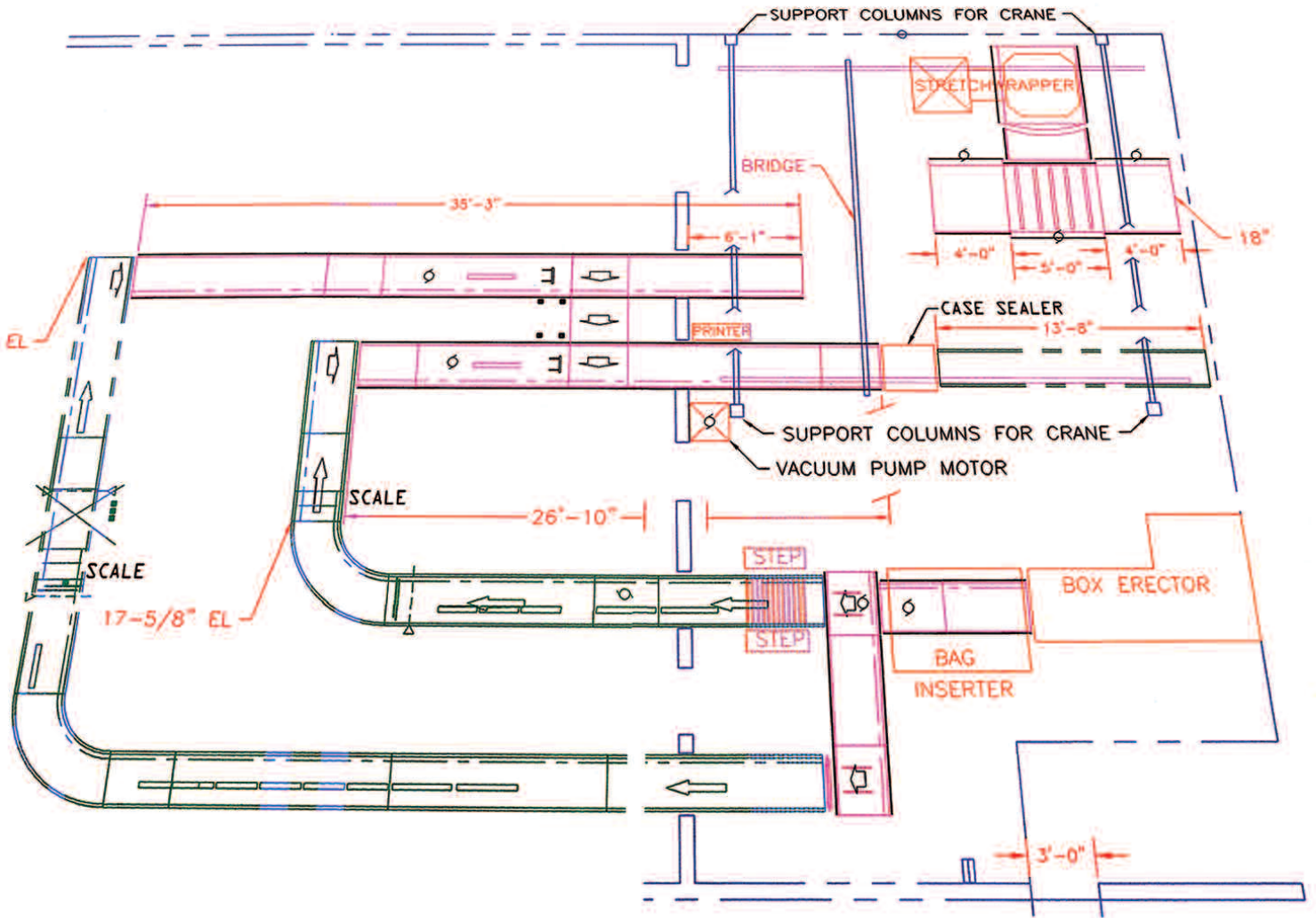

TPS Technical Packaging
Systems, Inc.

An Associate-Owned Company

269.342.4000 800.951.9100

Complete & Integrated Packaging Solutions

From site analysis through installation, start-up and training, we work with you to ensure system success. Our Systems Specialist will assist your company in the development of your integrated systems. We employ computer-aided drafting and detailing, design systems controls, provide project management, handle supplier coordination, and manage installation, start-up and training.

We take responsibility to ensure your system performs to meet your needs and expectations. Please contact our systems specialist today to explore how our services may fit your needs.

When you need to integrate packaging and material handling systems, it is the experience of the suppliers that determines capability. Turnkey results are what you get when we tackle your packaging/material handling needs. The combination of our best-of-the-best suppliers coupled with our trained staff of engineers produce proven results that will make your project a huge success.



Conveyorized Stretch Wrap System

Pallet Unitization Systems

- Stretch Wrapping Machinery
- Pallet Strapping Systems
- Palletizers
- Lift Tables
- Conveyor Systems



Pallet Transfer

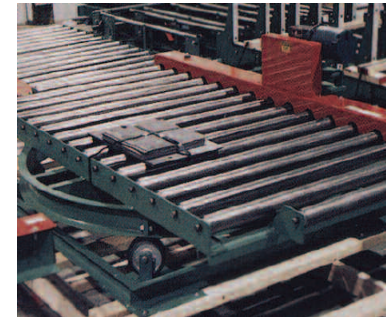

90° Pallet Rotation Station

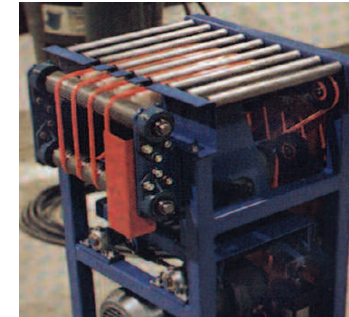

4-Way Carton Transfer

Pallet Handling Systems

- Pallet Conveyor
- Slip Sheet Conveyor
- Pallet Dispensers/Stackers
- Pallet Transfers
- Pallet Rotating Devices
- Automatic Pallet Storage Systems
- Automatic Palletizing

Case Erecting, Packing and Sealing Systems

- Case Sealers
- Case Erectors & Formers
- Case Poly Bag Inserters
- Case Packers
- Case Palletizers
- Plastic Strapping Equipment



Case Packing & Sealing



High-resolution printing

Case Coding Systems

- Ink Jet Printers
- Print & Apply Label Systems
- RF Applications & Verification
- High Resolution Printing & Bar Coding
- Visual Identification

Packaging Systems

- Vertical Form Fill Seal
- Stick Pack
- Sachet Machines
- Premade Pouch Packaging Machines
- Ancillary Equipment



Vertical Form Fill Seal

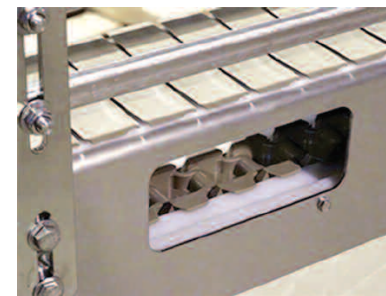

Vertical Form, Fill & Sealing

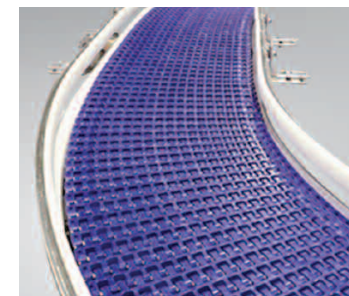

Carton/Case Conveyors



Specialty Conveyors



Specialized Product Handling

System Controls

- Traffic Control
- Separation & Speed Control Systems
- Positive Flight & Positioning Systems
- Identification Code Reading Systems
- Vertical Lifts



Checkweighing

Inspection Systems

- X-Ray Inspection Systems
- CheckWeighers
- Metal Detection
- Combination CW & MD Systems
- Rejector Systems

Shrink Packaging, Bundling, Bagging & Overwrapping

- Shrink Packaging Systems
- Banding Machinery
- Stretch Bundling Systems
- Form, Fill & Seal Machinery
- Bagging Systems
- Bundling Machinery



Multi-packing equipment

Installation & Start-up To Meet Your Needs.

- Machinery Assembly & Placement
- Electrical & Pneumatic Piping
- Fences, Gates, Safety Devices
- Conveyors
- Software Integration
- Training/Start-up Supervision

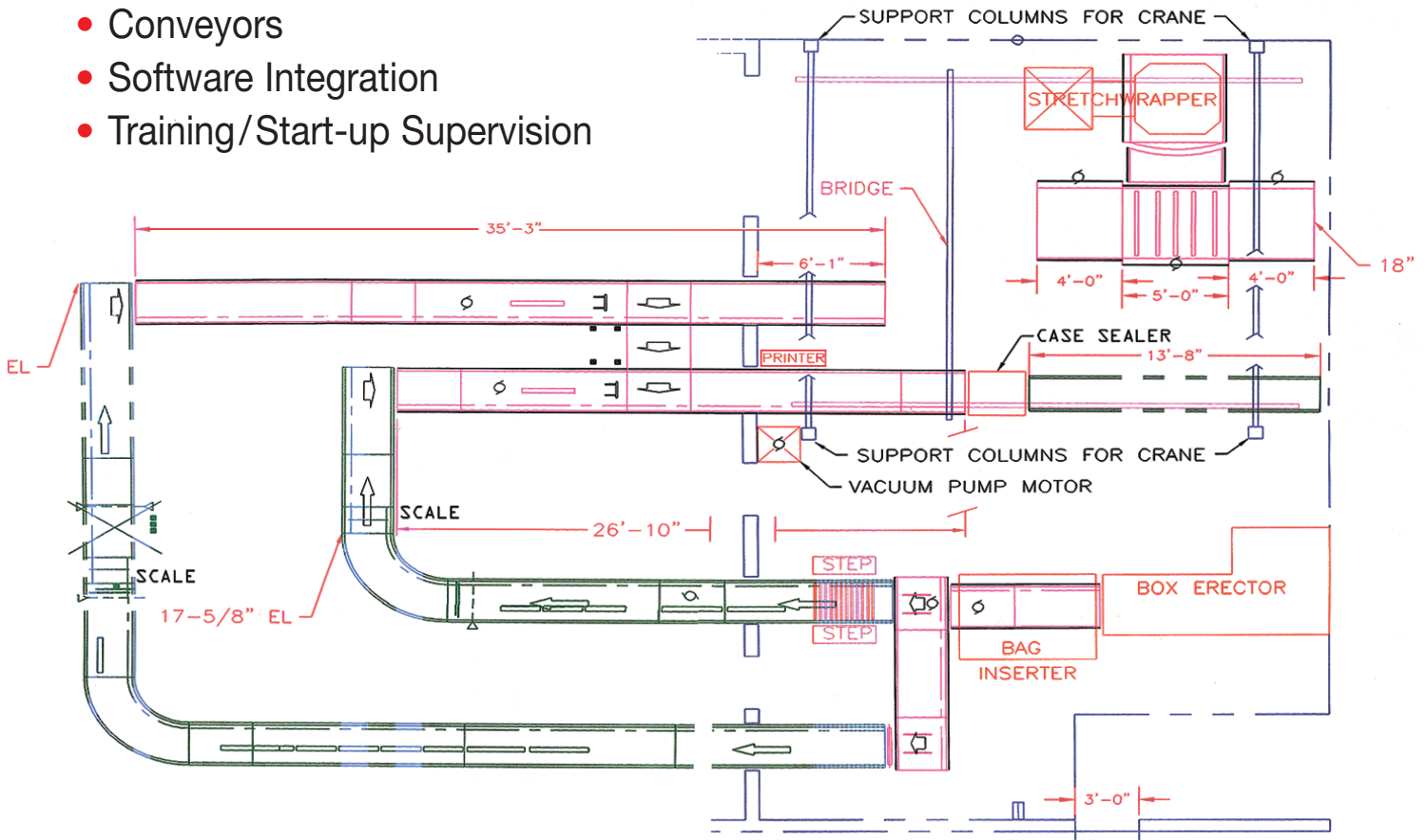

We are dedicated to bringing our customers the best solutions with the products we represent. Our focus is on machinery, and technical service to keep your systems operating efficiently.

Our engineering and service staff have over 150 years of combined experience in packaging & material handling— and we are ready to bring you the latest developments in the products we represent. Yes, we can **improve** your efficiency and quality— and reduce your cost. There is always a better way if we work together with integrated product and process.



TPS Technical Packaging
Systems, Inc.

An Associate-Owned Company

6389 Valley Industrial Dr. – Kalamazoo, MI 49009
Phone 269.342.4000 – Toll-Free 800.951.9100 – Fax 269.342.8558 – technicalpackaging.com